



CAMPBELL®

CHAIN & FITTINGS

Campbell Eye Hoist Hooks have been redesigned from the ground up to offer the latest in durability and ease of use. A new heavy-duty latch and spring assembly features extra-thick steel construction, a double-strength spring, and a stainless steel latch bolt — all mounted on dual forged support bosses — providing the toughest eye hoist hook Campbell has ever made. That's Campbell Confidence at work.

- Heavy-gauge high strength steel latch with reinforcing rib for ultimate rigidity and bending resistance
- Double-strength spring holds latch firmly against hook to securely retain slings and hardware
- Integrated forged bosses provide lateral support for positive latch/hook alignment and engagement
- Latch features yellow chromate finish, providing optimal corrosion resistance
- Latch marking forged into hook for easy replacement ordering
- Carbon steel hooks are painted blue or galvanized to ASTM A-153 specifications; alloy hooks are painted orange
- Design factor: 5 to 1

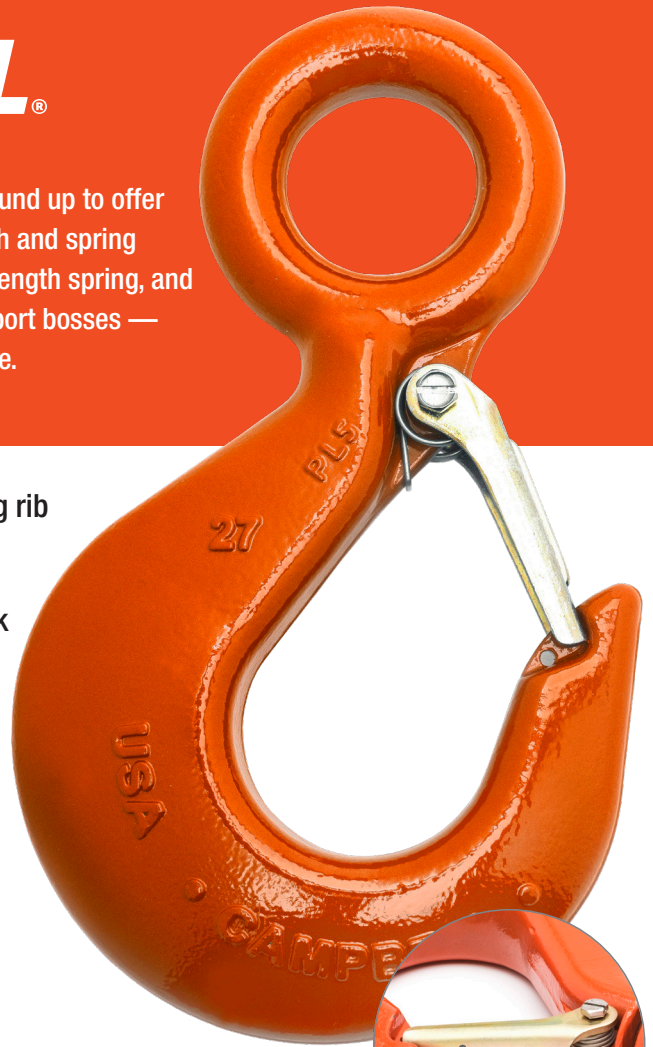

Heavy-gauge high strength latch

2X stronger spring

Latch marking forged into hook

45-degree indicators forged into hook

Dual boss latch/spring support

Eye Hoist Hooks



Trade Size	Working Load Limit (Short Tons)		Catalog Number				Replacement Latch No.	Latch Marking
	Carbon Steel	Alloy Steel	Carbon Steel Latched	Carbon Steel Galv Latched	Alloy Steel Latched	Alloy Steel Regular		
22	3/4	1	3914205PL	3914235PL	3924215PL	—	7506295PL	PL-3
23	1	1-1/2	3914305PL	3914335PL	3924315PL	—	7506295PL	PL-3
24	1-1/2	2	3914405PL	3914435PL	3924415PL	—	7506495PL	PL-4
25	2	3	3914505PL	3914535PL	3924515PL	—	7506495PL	PL-4
27	3	5	3914705PL	3914735PL	3924715PL	3922715PL	7506695PL	PL-5
29	5	7	3914905PL	—	3924915PL	3922915PL	7506895PL	PL-7
31	7-1/2	11	3915105PL	—	3925115PL	3923115PL	7507095PL	PL-8
32	—	15	—	—	3925215PL	3923215PL	7507295PL	PL-9

Eye Hoist Hooks

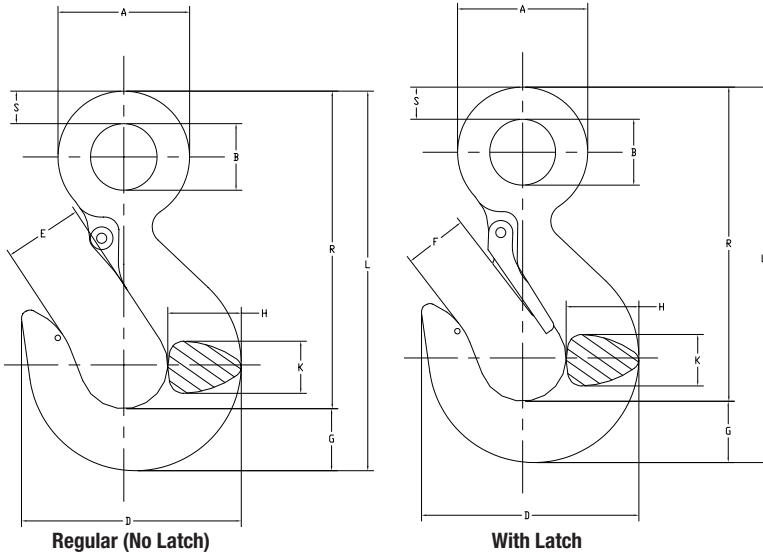

Trade Size	A Dim	B Dim.	D Dim.	E Dim.	F Dim.	G Dim.	H Dim.	K Dim.	L Dim.	R Dim.	S Dim.
22	1-19/32 in	27/32 in	3 in	1-1/4 in	15/16 in	3/4 in	29/32 in	21/32 in	5-3/16 in	4-7/16 in	3/8 in
23	1-25/32 in	15/16 in	3-13/32 in	1-1/4 in	1 in	29/32 in	1-1/8 in	25/32 in	5-19/32 in	4-11/16 in	7/16 in
24	2-1/4 in	1-1/8 in	3-3/4 in	1-11/32 in	1-3/32 in	1-1/16 in	1-1/4 in	29/32 in	6-15/32 in	5-13/32 in	17/32 in
25	2-7/16 in	1-9/32 in	4-1/8 in	1-13/32 in	1-5/32 in	1-1/4 in	1-1/2 in	1 in	6-31/32 in	5-23/32 in	19/32 in
27	3 in	1-9/16 in	5 in	1-11/16 in	1-3/8 in	1-15/32 in	1-7/8 in	1-13/32 in	8-7/16 in	6-31/32 in	23/32 in
29	3-13/16 in	2 in	6-3/16 in	2-1/16 in	1-21/32 in	1-27/32 in	2-7/32 in	1-21/32 in	10-1/2 in	8-21/32 in	29/32 in
31	4-11/16 in	2-7/16 in	7-9/16 in	2-17/32 in	2-1/32 in	2-9/32 in	2-23/32 in	2 in	12-13/16 in	10-17/32 in	1-1/8 in
32	5-13/32 in	2-27/32 in	8-3/4 in	2-3/4 in	2-9/32 in	2-19/32 in	3-1/8 in	2-1/4 in	14-11/32 in	11-3/4 in	1-9/32 in

Replacement Latch No.	Latch Marking
7506295PL	PL-3
7506495PL	PL-4
7506695PL	PL-5
7506895PL	PL-7
7507095PL	PL-8
7507295PL	PL-9
7507495PL	PL-10

